

800.364.7681



www.DOGIPARK.com

The **Smart** Dog Park Solution.  
A DOGIPOT® Brand.

**PLAYGROUNDS FOR DOGS™**

### BONE LEASH POST (ITEM# 7732)

## SPECIFICATION AND INSTALLATION SHEET



#### YOUR **PLAYGROUNDS FOR DOGS™** BONE LEASH POST INCLUDES:

- Powder coated Green Bone leash post
- 1 Black powder coated in-ground mounting base
- Mounting hardware (4) 1¼" x 5/16" bolts, (8) 5/16" washers & (4) 5/16" Nuts

**PLEASE CHECK THE ABOVE INVENTORY AND CALL YOUR DISTRIBUTOR IF ANY PARTS ARE MISSING.**

### INSTALLATION AND OPERATION INSTRUCTIONS

1. Select a good level spot to install
2. Assemble the in-ground mount base to the bone leash post with included hardware.
3. Dig 1 hole 18" deep using the attached in-ground mounting base to determine the exact location. We suggest using a fast setting concrete for the best results.
4. We recommend adding mulch around the footer.

*Surface mounting – please surface mount per your requirements using your own hardware.*

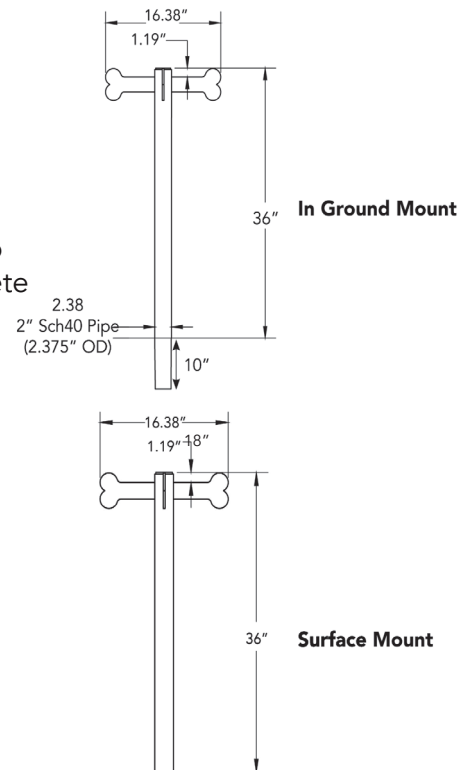

## PLAYGROUNDS FOR DOGS™

### BONE LEASH POST (ITEM# 7732)

## SPECIFICATION AND INSTALLATION SHEET



### PRODUCT DETAILS:

#### Dimensions:

- 36" H x 16.38" W x 2.375" D (In Ground Mount)

#### Surface and Material:

- 2.0" Schedule 40 pipe (2.375" O.D.)
- Green powder coating
- Applied at a thickness of 25-30 mils.
- 5 year warranty on coating
- Total weight 22.98 lbs.

### SAFETY WARNINGS AND EQUIPMENT MAINTENANCE RECOMMENDATIONS

- **PLEASE READ THESE IMPORTANT SAFETY WARNINGS AND KEEP ON FILE FOR FUTURE REFERENCE REGARDING INSPECTION REMINDERS AND LIST OF PARTS.**
- Follow installation instructions and find a safe, suitable location for equipment use.
- All products should be in-ground or surface mounted and securely fastened to concrete. Concrete footers should never protrude above the ground where they are exposed and could create a safety hazard. Ground covering, such as mulch, is recommended over the buried footers.
- Regular scheduled review of equipment should be conducted to ensure there is no existing damage caused by wear and tear, improper use or vandalism.
- All equipment should be free from rust or other structural damage. Replace or repair in the event any rust exists that could affect the structural integrity of the equipment.
- Any areas where the coating has been removed should be repainted to deter rusting or other damage.
- Any protruding bolts, rough or sharp edges should be covered, capped or removed. Inspect for broken, bent or worn pieces and replace if present.
- Never add components not intended for this equipment. **EQUIPMENT IS NOT INTENDED FOR USE BY PEOPLE. THE EQUIPMENT IS SOLELY INTENDED AND DESIGNED FOR DOG USE ONLY.**
- Proper and regular maintenance of equipment includes, but is not limited to, inspection of footings, all bolts and connection points, edges, landing areas, coatings and surfaces. This includes regular tightening of bolts, nuts and screws.
- **ANY WORN OR BROKEN PARTS, BOLTS, NUTS, SCREWS, INSTABILITY IN THE FOOTERS AND THE LIKE SHOULD BE REPLACED IMMEDIATELY TO PREVENT ANY INJURY.**

### WARRANTY

DOGIPOT<sup>®</sup> warrants to the original consumer purchaser that our DOGIPARK<sup>®</sup> brand products will be free from defects in material workmanship under normal use for a period of two (2) years from the date of purchase when installed and maintained properly.

DOGIPOT<sup>®</sup> may elect to repair or replace any defective DOGIPARK<sup>®</sup> product covered by our warranty. Our warranty does not cover defects caused by misuse, abuse, vandalism, negligence, alterations, environmental conditions, extreme weather conditions, manmade or natural disasters, lack of maintenance, improper installation, storage or handling or normal wear and tear from use.

DOGIPOT<sup>®</sup> provides a limited warranty for the RUFFCOAT™ and Thermoplastic coated elements for 5 years.

Damages or loss in transit is the responsibility of the carrier, whether visible or concealed. It is the responsibility of the recipient to ensure that the order is received both complete and without damages. Before signing receipt, inspect the shipment immediately and completely. Note any damages or shortages on the bill of lading. Damage reports must be filed within ten (10) days. DOGIPOT<sup>®</sup> is not responsible for lost damages or loss in transit. Title to all goods passes to the customer at the time of shipment. DOGIPOT<sup>®</sup> will assist in filing claims if the freight arrangement was made by DOGIPOT<sup>®</sup> at your request. Cancellations and returns are only accepted with the approval of DOGIPOT<sup>®</sup>. No equipment shall be returned without a Return Materials Authorization which is issued by customer service. Any returned equipment must be returned in the original packaging and wrapped and stuffed to avoid damage, or in a similar suitable condition. A restocking charge of up to 25% will be applied to all returned goods when the error is not that of DOGIPOT<sup>®</sup>. The customer is responsible for all freight charges to return any equipment.